

SPECIFICATIONS **CL50R3D**
OUTLINES DIMENSIONS
Description

- *Round Type
- *T1-3/4 (5mm) Diameter
- *Lens Color: Red Diffused
- *With Flange

Features

- *Emitted Color: Red
- *High Luminous Intensity
- *Technology: InGaAlP
- *Peak Wavelength = 630nm

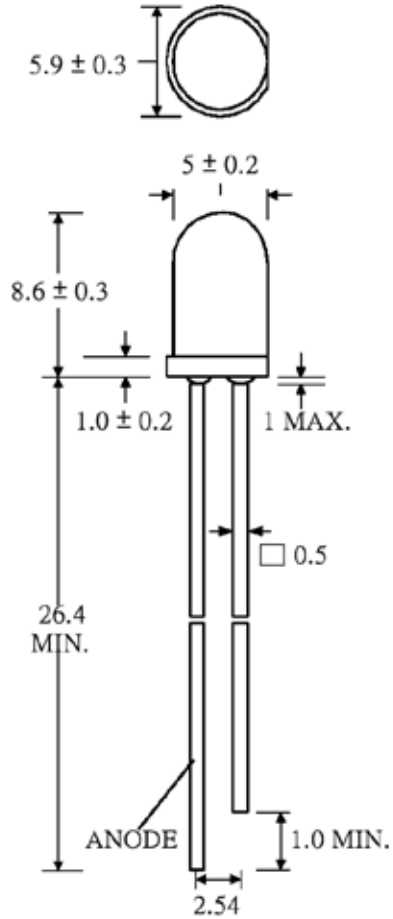

- Notes:
1. All Dimensions are in millimeters (inches).
 2. Tolerance is $\pm 0.25\text{mm}$ (0.01") unless otherwise noted.
 3. Specifications are subject to change without notice.

Part Number	Chip Material	Color of Emission	Lens Type	Viewing Angle
CL50R3D	InGaAlP	Red	Red Diffused	50°



ChromeLED Corp. reserves the right to make changes at any time in order to supply the best product possible. The most current version of this document will always be available at: www.chromeled.com

